

150  
PSI

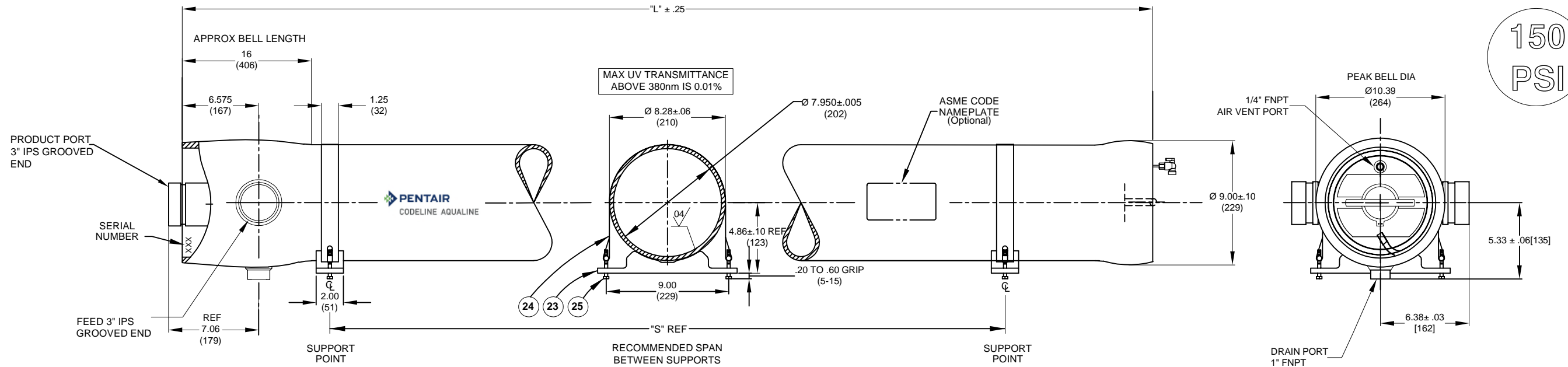

DWG REF	QTY	PART NUMBER	DESCRIPTION	MATERIAL
<b>SHELL</b>				
1*	1	17219	SHELL	Filament Wound Epoxy/Glass composites - Head locking grooves integrally wound in place.
2*	A/R	96327	3" Feed Port	SA-995 CD3MMVCuN (UNS J93380)
3	A/R	196141	3" Port Seal	Sq-Seal-EPDM
4*	1	17180	1" FNPT Drain Port	SA-995 CD3MMVCuN (UNS J93380)
5	1	45340	1" Port Seal	Sq-Seal-EPDM
<b>HEAD</b>				
6	1	17433	1/4" FNPT Air Vent Port	SA-479 UNS S32760
7	2	196208	1/4" Air Vent Port Seal	O - Ring - EPDM
8	1	194940	Bearing Plate Assembly Handle End	
8.1*	1	17179	Bearing Plate Handle End	SB-221 A96061-T6
8.2	1	17413	Danger Label Handle End	-
9	1	117007	Sealing Plate Handle End	Engineering Thermoplastic-Noryl
10	1	194941	Bearing Plate Assembly Product	
10.1*	1	17103	Bearing Plate Product End	SB-221 A96061-T6
10.2	1	17173	Danger Label Product End	-
11	1	17126	Sealing Plate Product End	Engineering Thermoplastic-PVC*
12	1	PWG17434	3" Product Port	SA-995 CD3MMVCuN (UNS J93380)
13.1	1	PWG17432	3" Product Port Adapter	Engineering Thermoplastic-PVC*
13.2	1	17435	Product port holding pin	Engineering Thermoplastic
14	2	17164	3" Seal for Product Port Adapter	O - Ring - EPDM
15	1	17127	3" Port Retaining Ring	SA-479 316
16	2	196223	Head Seal	O - Ring - EPDM
17	1	17128	Product Port Seal	O - Ring - EPDM
18	1	17104	Handle Assembly	SA-479 316
19	1	45247	Plug Retaining Ring	Stainless Steel
20	1	17132	Plug	Engineering Thermoplastic - PVC*
21	1	196215	Plug seal	O - Ring - EPDM
<b>HEAD INTERLOCK</b>				
22*	2	47336	Quick Release Retaining Ring	SA-479 316
<b>VESSEL SUPPORT</b>				
23	2	52169	Saddle	Engineering Thermoplastic
24	2	45042	Strap Assy.	304 Stainless Steel-PVC Cushion.
25	4	46265	Strap screw.	5/16-18 UNC X 2.5" - Long, 304 Stainless Steel.

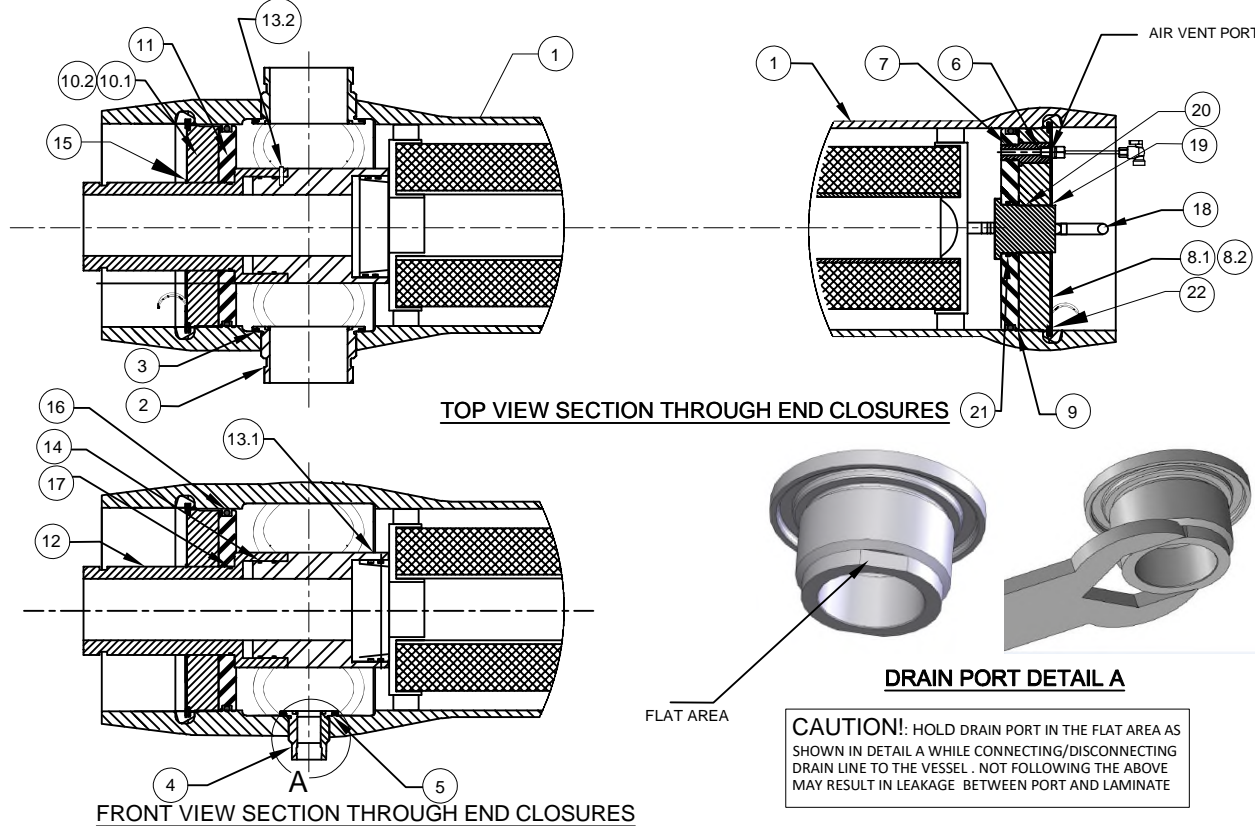

CAUTION: INCORRECT MANIFOLDING WILL CAUSE SEVERE LOCAL STRESS AROUND PORT AND MAY RESULT IN LEAKS AND PREMATURE FAILURE; TAKE EVERY PRECAUTION LISTED ON REVERSE, SEE INSTALLATION INSTRUCTIONS FOR FURTHER DETAILS

PORT SIZE CODE	
A	1" FNPT END
G	3" GROOVED END

NO. OF PORTS	PORT LOCATION	VESSEL QTY.		
<b>AIR VENT ASSEMBLY:- 17185</b>				
ITEM	QUANTITY	PART NO.	DESCRIPTION	
1	6" Long	RRS-01027	Tubing Blue	
2	1	RRS-010013	Male Connector, Pipe 1/4" Tube 1/4"	
3	1	RRS-01047	Compression nut 1/4"	
4	1	RRS-01039	Ball Valve 1/4"	
5	1	17194	Blind Plug 1/4"	
Element	"L" IN(MM)	"S" IN(MM)	Approx Weight LB(KG)	Approx Weight With Filter LB(KG)
40	53.94 (1370)	21X1 (533)	51 (23)	64 (30)
60	74.62 (1896)	42X1 (1067)	60 (27)	73 (33)

**GENERAL NOTES:**

1. DIMENSION IN INCHES (MM APPROX.).
  2. SHELL EXTERIOR COATED WITH WHITE RAL 9003, HIGH GLOSS POLYURETHANE PAINT.
  3. NOT TO BE USED FOR CONSTRUCTION UNLESS CERTIFIED BY PENTAIR.
- +OPTIONAL MATERIAL SELECTION AVAILABLE FOR 180°F APPLICATION ON SECOND PAGE.  
\* ASME PARTS.

THIS DOCUMENT AND THE INFORMATION CONTAINED HEREIN, ARE THE CONFIDENTIAL AND PROPRIETARY INFORMATION OF PENTAIR WATER INDIA PVT. LTD. PENTAIR WATER INDIA PVT. LTD. IS THE SOLE OWNER OF THE INFORMATION AND PROCESSES DEFINED HEREIN. THIS DOCUMENT, AND THE INFORMATION CONTAINED, MAY NOT BE DISCLOSED, REPRODUCED, DUPLICATED, USED, SOLD, PUBLISHED, COMMUNICATED OR OTHERWISE DISTRIBUTED, IN WHOLE OR IN PART, FOR ANY PURPOSE WITHOUT THE EXPRESS WRITTEN CONSENT OF PENTAIR WATER INDIA PVT. LTD. THIS DOCUMENT AND ANY COPIES, IN ALL APPLICABLE FORMATS, SHALL BE RETURNED TO PENTAIR WATER INDIA PVT. LTD. UPON REQUEST.

ALL INDICATED PENTAIR TRADEMARKS AND LOGOS ARE PROPERTY OF PENTAIR. THIRD PARTY REGISTERED AND UNREGISTERED TRADEMARKS AND LOGOS ARE PROPERTY OF THEIR RESPECTIVE OWNERS. BECAUSE WE ARE CONTINUOUSLY IMPROVING OUR PRODUCTS AND SERVICES, PENTAIR RESERVES THE RIGHT TO CHANGE SPECIFICATIONS WITHOUT PRIOR NOTICE. PENTAIR IS AN EQUAL OPPORTUNITY EMPLOYER.



DRAWN BY: AND	DATE: 22SEPT10	DRAWING DESCRIPTION: MODEL: 80CF15 SINGLE CARTRIDGE HOUSING	DRAWING NO.: 17036	REV.: Q
CHECKED BY: RD	DATE: 22SEPT10	CUSTOMER NAME:	VESSEL MODEL: 80CF15 (CODED)	
APPROVED BY: RM	DATE: 22SEPT10	PROJECT NAME:	TOTAL QTY: -	
ECN NO.: 6339	REV. DATE: 23JAN22	CUSTOMER P.O.#:	SIZE: A3	SCALE: NONE
				PAGE NO.: 01 OF 02

**RATING:**  
 DESIGN PRESSURE.....**PVC/PET**  
 150 PSIG at 140°F/180°F  
 (1.03 MPa at 60°C/82°C)  
 MIN. OPERATING TEMP .....20°F  
 (-7°C)  
 FACTORY TEST PRESSURE.....**CE/ASME**  
 225 PSIG/165 PSIG  
 (1.55 MPa/1.14 MPa)  
 QUALIFICATION PRESSURE.....900 PSI  
 (6.21 MPa)

**INTENDED USE:**  
 The AquaLine 80CF15 Fiberglass Pressure Vessel is designed for continuous, long-term use as housing for AquaLine range of micro filtration elements.

The AquaLine 80CF15 is designed in accordance with the engineering standards of the Boiler and Pressure Vessel Code of the American Society of Mechanical Engineers (ASME) as per Section X Edition 2021 and all metallic parts are designed as per ASME Section VIII Division I Edition 2021. At small additional cost vessels can be inspected during construction by an ASME Authorized Inspector and ASME Code stamped.

The AquaLine 80CF15 must be installed, operated and maintained in accordance with the listed precautions and good industrial practice to assure safe operation over a long service life.

The high-performance Filament wound FRP shell must be allowed to expand under pressure; undue restraint at support points or piping connections can cause leaks to develop in the shell. This side-ported vessel requires special precautions in mounting and connection to piping so that the vessel will not be subjected to excessive stress due to bending moments acting at the side openings in the fiberglass shell. The end closure, incorporating close fitting, interlocking metal components, must be kept dry and free of corrosion; deterioration can lead to catastrophic mechanical failure of the head.

Pentair will assist the purchaser in determining the suitability of this standard vessel for their specific operating conditions. The final determination however, including evaluation of the standard material of construction for compatibility with the specific corrosive environment, shall be the responsibility of the purchaser. Alternate materials with enhanced corrosion resistance are available on special order.

Specifications are subject to change without notice.

**PRECAUTIONS:**

DO...read, understand and follow all instructions; failure to take every precaution will void warranty and may result in vessel failure.

DO...mount the shell on horizontal members at span "S" using compliant vessel supports furnished; Shim saddles if required. Tighten hold down straps just snug

DO...align and center side ports with the manifold header. Correct, causes of misalignment in a row of vessels connected to the same header.

DO...use flexible type IPS grooved-end pipe couplings, or equal, at side ports; allow full, 0.125-inch gap between port and piping, and position piping to maximize flexibility of connection.

DO...provide flexibility in, and support for piping manifolds so that vessel can grow in length under pressure without undue restraint; provide additional flexible joints in large pipes leading to manifold header.

DO... Lubricate seals sparingly, using nonpetroleum Based lubricants, i.e., Parker Super O-lube®, Glycerin or suitable silicone based lubricants.

DO...provide overpressure protection for vessel set at not more than 105% of design pressure.

DO...inspect end closures regularly; replace components that have deteriorated and correct causes of corrosion.

DO NOT...work on any component until first verifying that pressure is relieved from vessel.

DO NOT...make rigid piping connections to ports or clamp vessel in any way that resists growth of fiberglass shell under pressure.

DO NOT...pressurize vessel until double-checking to verify that the Locking Ring is in place and fully seated.

DO NOT...operate vessel at pressure and temperature in excess of its rating.

DO NOT...tolerate leaks or allow end closures to be routinely wetted in any way.

DO NOT...operate outside the pH range of 3-11.

**ORDERING:**

Using the chart below, please check the features you require and fax them with your purchase order to our customer service department for further processing. For optional materials and / or feature not listed below, please consult the factory for pricing and availability.

**VESSEL LENGTH CODE – please check one**

**MODEL:** AquaLine 80CF15  -40  -60

**CERTIFICATION REQUIRED**

**Hydro testing at 1.1 times the design pressure.**  
 **In compliance with the ASME Sec X but not Code Stamped.**  
 ASME Stamped and National Board Registered.

Hydro testing at 1.5 times the design pressure.  
 CE Marked.

**HEAD ASSEMBLY MATERIAL SELECTION**

**Standard: For 140°F application, Engineering Thermoplastic components in PVC as per drawing on First page.**  
 Option: For 180°F application, Engineering Thermoplastic components in PET as given below. (Please consult factory as these options will affect pricing and vessel lead-time).

HEAD COMPONENTS FOR 180°F APPLICATION				
DWG REF	QTY	PART NUMBER	DESCRIPTION	MATERIAL
6	1	17433	1/4" FNPT Air Vent Port	SA-479 UNS S32760.
7	2	196208	1/4" Air Vent Port Seal	O - Ring - EPDM
8	1	194942	Bearing Plate Assembly Downstream	
8.1*	1	17179	Bearing Plate Downstream	SB-221 A96061-T6
8.2	1	17198	Danger Label Downstream	-
9	1	117007	Sealing Plate Downstream	Engineering Thermoplastic - Noryl.
10	1	194943	Bearing Plate Assembly Upstream	
10.1*	1	17103	Bearing Plate Upstream	SB-221 A96061-T6
10.2	1	17197	Danger Label Upstream	-
11	1	17453	Sealing Plate Upstream	Engineering Thermoplastic - PET.
12	1	PWG17434	3" Product Port	SA-995 CD3MWCuN (UNS J93380)
13.1	1	17452	3" Product Port Adapter	Engineering Thermoplastic - PET.
13.2	1	17435	Product port holding pin	Engineering Thermoplastic
14	2	17164	3" Seal for Product Port Adapter	O - Ring - EPDM
15	1	17127	3" Port Retaining Ring	SA-479 316
16	2	196223	Head Seal	O - Ring - EPDM
17	1	17128	Product Port Seal	O - Ring - EPDM
18	1	17104	Handle Assembly	SA-479 316
19	1	45247	Plug Retaining Ring	Stainless Steel
20	1	17407	Plug	Engineering Thermoplastic - PET.
21	1	196215	Plug seal	O - Ring - EPDM

**FEED PORT CONFIGURATION**

Please fill out quantity for each configuration

- 1A 4G – (Standard)**  
 1A 2G – (Optional)  
 1A 2G 4G – (Optional)

For complete information on proper use of the vessel  
 Please refer to the AquaLine User Guide No. 97676.

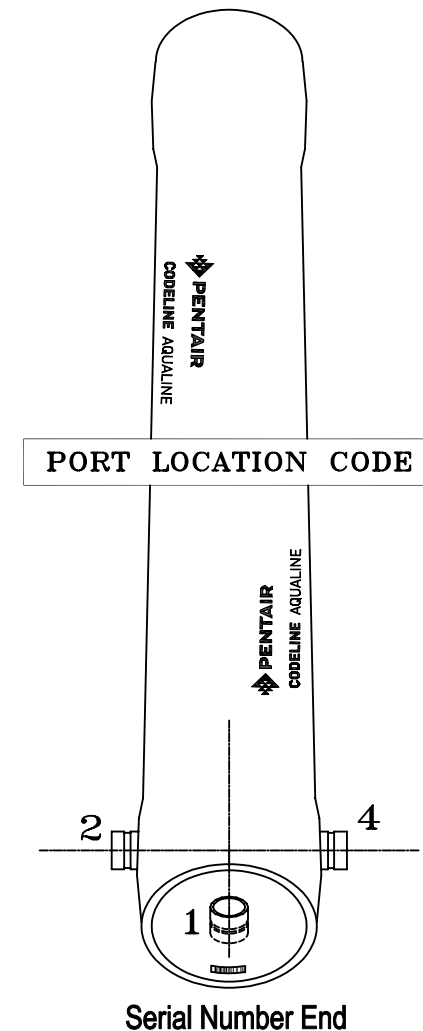

\* ASME PARTS.

THIS DOCUMENT AND THE INFORMATION CONTAINED HEREIN, ARE THE CONFIDENTIAL AND PROPRIETARY INFORMATION OF PENTAIR WATER INDIA PVT. LTD. PENTAIR WATER INDIA PVT. LTD. IS THE SOLE OWNER OF THE INFORMATION AND PROCESSES DEFINED HEREIN. THIS DOCUMENT, AND THE INFORMATION CONTAINED, MAY NOT BE DISCLOSED, REPRODUCED, DUPLICATED, USED, SOLD, PUBLISHED, COMMUNICATED OR OTHERWISE DISTRIBUTED, IN WHOLE OR IN PART, FOR ANY PURPOSE WITHOUT THE EXPRESS WRITTEN CONSENT OF PENTAIR WATER INDIA PVT. LTD. THIS DOCUMENT AND ANY COPIES, IN ALL APPLICABLE FORMATS, SHALL BE RETURNED TO PENTAIR WATER INDIA PVT. LTD. UPON REQUEST.

ALL INDICATED PENTAIR TRADEMARKS AND LOGOS ARE PROPERTY OF PENTAIR. THIRD PARTY REGISTERED AND UNREGISTERED TRADEMARKS AND LOGOS ARE PROPERTY OF THEIR RESPECTIVE OWNERS. BECAUSE WE ARE CONTINUOUSLY IMPROVING OUR PRODUCTS AND SERVICES, PENTAIR RESERVES THE RIGHT TO CHANGE SPECIFICATIONS WITHOUT PRIOR NOTICE. PENTAIR IS AN EQUAL OPPORTUNITY EMPLOYER.

© 2021 Pentair. All Rights Reserved.



VERNA, GOA  
INDIA

DRAWN BY:	AND	DRAWING DESCRIPTION:	DRAWING NO.:	REV.:
DATE:	22SEPT10	MODEL: 80CF15 SINGLE CARTRIDGE HOUSING	17036	Q
CHECKED BY:	RD	CUSTOMER NAME:	VESSEL MODEL: 80CF15 (CODED)	
DATE:	22SEPT10	PROJECT NAME:	TOTAL QTY:	
APPROVED BY:	RM	CUSTOMER P.O.#:	SIZE:	SCALE:
DATE:	22SEPT10		A3	NONE
ECN NO.:	6339			PAGE NO.:
REV. DATE:	23JAN23			02 OF 02